



FS9721_LP3

4,000 counts auto range DMM IC.

Data Sheet

FS9721_LP3-DS-18_EN

Rev. 1.8

This manual contains new product information. **Fortune Semiconductor Corporation** reserves the rights to modify the product specification without further notice. No liability is assumed by **Fortune Semiconductor Corporation** as a result of the use of this product. No rights under any patent accompany the sale of the product.

CR-004

CONTENT

	PAGE
1. Introduction	3
2. Features	3
3. Measurable Modes	3
4. Application Field	4
5. Block Diagram	4
6. Pin Diagram	5
7. Pin Description	5
8. Dice Pad Layout & Pad Coordinate	8
9. Technical Specification	9
10. Measurement Mode Select	11
11. Keys Definition	12
12. Other Functions	13
13. RS232 Transmission Protocol	13
14. LCD Display	14
15. Application Description	15
16. Package Outline	27
17. Demo Board	28
18. Ordering Information.....	32
19. Revision History	33



FS9721_LP3

4,000 counts auto range DMM IC.

1. Introduction

FS9721_LP3 is a high performance, low power consumption and 3 ³/₄ digits (4000 Counts) Analog to Digital Converter that built-in the microprocessor (ADC+MCU). It includes the 8 bits microprocessor, low noise and high stability OPAMP, AC rectifier OPAMP, voltage promotion and regulated voltage power, high regulated bandgap, auto measurement switch and function control circuit, buzzer driver circuit, clock oscillation circuit, backlight display control circuit, LCD display driver circuit and so on.

With the microprocessor, FS9721_LP3 can process the logic function control via I/O ports, and through the codes of MEA1~MEA4 pins, it can assemble various measurement functions, as well as construct fully auto measurement meter through the code settings. For the settings of Range, Select, Hold, Rel, BLCTR, Hz/Duty and Reset keys, it can be fulfilled the measurement mode select, function switch, reading hold, relative value measurement, backlight display, frequency and duty cycle measurement, reset and so on functions by triggering these keys.

FS9721_LP3 has the serial data output function so that users can connect the meter and the equipment of computer for recording, analyzing, processing and printing the measuring data.

With regard to the auto power off function, when there is no action within 30 minutes on the switch or keys of the meter, the system will enter the sleep mode automatically to save the power. In the process of using the meter, if it is not necessary to power off automatically, the function can also be cancelled in use.

FS9721_LP3 is made by large integrated circuit technology so that rise greatly up the reliability of the product, and make the design be simple and the volume be small. It takes low power voltage so as to be low power consumption and is convenient to use the power supply of battery, especially is proper for the use on the palm mode meter.

FS9721_LP3 is a microprocessor-embedded and multifunctional measuring ADC so that just less external components added, it can be a high accuracy, lots functions and low cost measuring meter.

2. Features

- 2.1 Max. Display: 4000 Counts (3 ³/₄ digits).
- 2.2 Conversion Rate: 3 times/sec.
- 2.3 The Negative Indication: Auto.
- 2.4 Power Voltage Range: 2.4V~3.6V.
- 2.5 Chip Power Consumption: ≤6mW.
- 2.6 Low Battery Warning: Approx. 2.4V.
- 2.7 Buzzer Driver Circuit (Frequency is about 2.7kHz).
- 2.8 RS232 Serial Data Output
- 2.9 Embedded OPAMP for AC/DC conversion.
- 2.10 Function Keys: Range, Hold/BLCTR, Rel, Select, Hz/Duty, RS232 and Reset.
- 2.11 Unit Symbol and Backlight Display.
- 2.12 Auto Power-off.

3. Measurable Modes

- 3.1 DC Voltage: 400.0mV, 4.000V, 40.00V, 400.0V, 1000V.
- 3.2 AC Voltage: 400.0mV, 4.000V, 40.00V, 400.0V, 1000V.
- 3.3 DC Current: 400.0μA / 4000μA, 40.00mA / 400.0mA, 10.00A.
- 3.4 AC Current: 400.0μA / 4000μA, 40.00mA / 400.0mA, 10.00A, 400.0A / 4000A.

- 3.5 Resistance: 400.0 Ω , 4.000k Ω , 40.00k Ω , 400.0k Ω , 4.000M Ω , 40.00M Ω .
- 3.6 Capacitance: 51.20nF,512.0nF,5.120 μ F,51.20 μ F,100.0 μ F(15Sec).
- 3.7 Frequency: 5.120Hz,51.20Hz,512.0Hz,5.120kHz,51.20kHz,512.0kHz,5.120MHz.
- 3.8 Duty Cycle: 0.1%~99.9%.
- 3.9 Diode: 0V~1.5 V.
- 3.10 Open-Short Test: Sound when lower than 50 Ω .

4. Application Field

- 4.1 Auto Measurement Palm Digital Multimeter.
- 4.2 Auto Measurement Card Digital Multimeter.
- 4.3 Auto Measurement Pen Digital Multimeter.
- 4.4 Auto Measurement Clinch Meter (Hook Meter, Clamp Meter, etc.).
- 4.5 Number Panel Meter.

5. Block Diagram

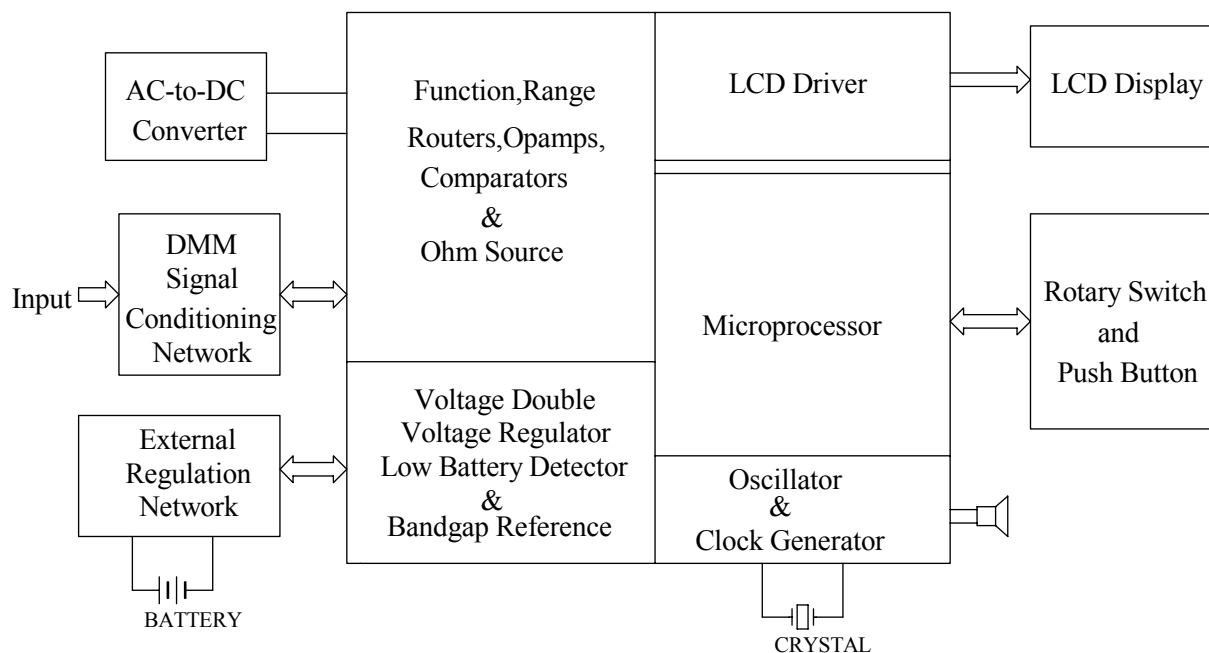

Diagram 1 Block Diagram

6. Pin Diagram

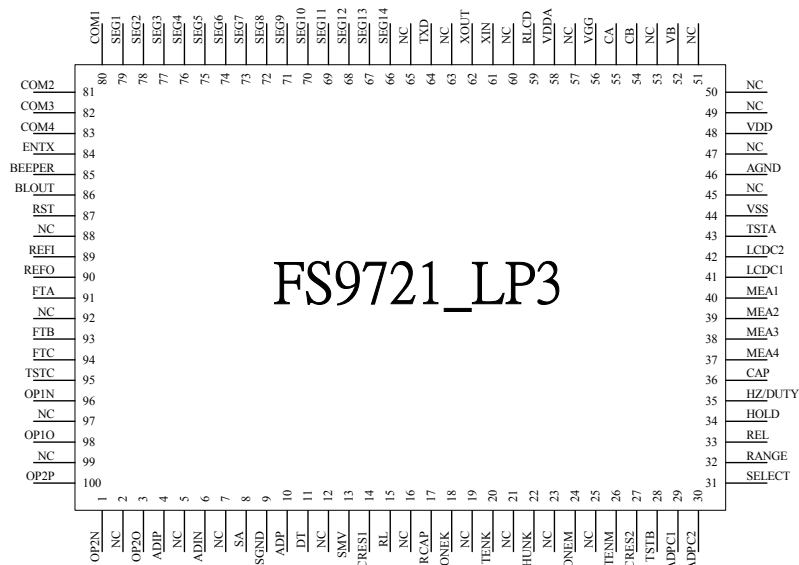

Diagram 2 100PIN Package

7. Pin Description

Package 100	Pad 78	SYMBOL	I/O	Description
1	1	OP2N	I	The Negative Input of DC/AC Converter Operation Amplifier
2		NC		Empty Pin
3	2	OP2O	O	Output of DC/AC Converter Operation Amplifier
4	3	AD1P	I	ADC Positive Input of AC Measurement
5		NC		Empty Pin
6	4	AD1N	I	ADC Negative Input of AC Measurement
7		NC		Empty Pin
8	5	SA	I	ADC Input of Current Measurement
9	6	SGND	I	ADC Negative Input of Analog Ground Connection
10	7	ADP	I	Additional ADC Positive Input
11	8	DT	I/O	Connecting Point of Voltage Division Resistance of Diode Measurement
12		NC		Empty Pin
13	9	SMV	I	High Resistance Voltage Input / ADC Positive Input of Resistance Measurement / Connecting Point of Voltage Division Resistance of Diode Measurement
14	10	CRES1	I/O	Wave Filter Capacitance Connecting Point of Measuring Point of Resistance Measurement
15	11	RL	I	The Negative Input of Voltage Reference of Resistance Measurement
16	12	NC		Empty Pin



FS9721_LP3

4,000 counts auto range DMM IC.

17	13	RCAP	I/O	Calibrating Resistance Connecting Point of Capacitance Measurement
18	14	ONEK	I/O	Resistance 1.001KΩ Connecting Point of Voltage and Resistance Measurement
19		NC		Empty Pin
20	15	TENK	I/O	Resistance 10.010KΩ Connecting Point of Voltage and Resistance Measurement
21		NC		Empty Pin
22	16	HUNK	I/O	Resistance 101.010KΩ Connecting Point of Voltage and Resistance Measurement
23		NC		Empty Pin
24	17	ONEM	I/O	Resistance 1.111MΩ Connecting Point of Voltage and Resistance Measurement
25		NC		Empty Pin
26	18	TENM	I/O	Resistance 10.000MΩ Connecting Point of Voltage and Resistance Measurement
27	19	CRES2	I/O	Capacitance Connecting Point of Regulated Voltage Source of Voltage and Resistance Measurement
28	20	TSTB	I	Current Measurement Mode Select (See 15.13 “Current Measurement”)
29	21	ADPC1	I	Max. Input Voltage 400mV/40mV Select (See 10.4)
30	22	ADPC2	I	Measure Signals DC/AC Select (See 10.4)
31	23	SELECT	I	Measurement Function Select
32	24	RANGE	I	Auto/Manual Switch Select
33	25	REL	I	Hold Relative Value
34	26	HOLD	I	Reading Hold/ Backlight Control
35	27	HZ/DUTY	I	Frequency/Duty Cycle Measurement Select
36	28	CAP	I	Capacitance Measurement Function Select
37	29	MEA4	I	Measurement Function Select
38	30	MEA3	I	Measurement Function Select
39	31	MEA2	I	Measurement Function Select
40	32	MEA1	I	Measurement Function Select
41	33	LCDC1	I	Self-defined Symbol Display Assembly with LCDC2 (See 10.3)
42	34	LCDC2	I	Self-defined Symbol Display Assembly with LCDC1 (See 10.3)
43	35	TSTA	I	Testing Pin
44	36	VSS	I	The Negative Input of Power Source
45		NC		Empty Pin
46	37	AGND	I	Analog Signal Ground Connection
47		NC		Empty Pin
48	38	VDD	I	The Positive Input of Power Source
49		NC		Empty Pin
50		NC		Empty Pin
51		NC		Empty Pin
52	39	VB	I	Bias Current Input
53		NC		Empty Pin
54	40	CB	I/O	The Negative Connecting Point of Double Voltage Capacitance
55	41	CA	I/O	The Positive Connecting Point of Double Voltage Capacitance



FS9721_LP3

4,000 counts auto range DMM IC.

56	42	VGG	O	Double Voltage Circuit Output
57		NC		Empty Pin
58	43	VDDA	O	Regulated Power Output/Analog Power Source
59	44	RLCD	I	The Connecting Point of LCD Driver Voltage Adjusting Resistance
60		NC		Empty Pin
61	45	XIN	I	Oscillator Connecting Point
62	46	XOUT	O	Oscillator Connecting Point
63		NC		Empty Pin
64	47	TXD	O	RS232 Serial Data Output
65		NC		Empty Pin
66	48	SEG14	O	Segment 14
67	49	SEG13	O	Segment 13
68	50	SEG12	O	Segment 12
69	51	SEG11	O	Segment 11
70	52	SEG10	O	Segment 10
71	53	SEG9	O	Segment 9
72	54	SEG8	O	Segment 8
73	55	SEG7	O	Segment 7
74	56	SEG6	O	Segment 6
75	57	SEG5	O	Segment 5
76	58	SEG4	O	Segment 4
77	59	SEG3	O	Segment 3
78	60	SEG2	O	Segment 2
79	61	SEG1	O	Segment 1
80	62	COM1	O	Backplane 1
81	63	COM2	O	Backplane 2
82	64	COM3	O	Backplane 3
83	65	COM4	O	Backplane 4
84	66	ENTX	I	RS232 Output Control
85	67	BEEPER	O	Buzzer Driver Output
86	68	BLOUT	O	Backlight Driver Output
87	69	RST	I	CPU Reset
88		NC		Empty Pin
89	70	REFI	I	ADC Voltage Reference Input
90	71	REFO	O	Bandgap Output
91	72	FTA	O	ADC Wave Pre-Filter Positive Output
92		NC		Empty Pin
93	73	FTB	I	ADC Wave Pre-Filter Positive Input
94	74	FTC	I/O	The Negative Terminal of ADC Wave Pre-Filter
95	75	TSTC	I	Testing Pin
96	76	OP1N	I	The Negative Input of AC Signal Buffer Operation Amplifier
97		NC		Empty Pin
98	77	OP1O	O	AC Signal Buffer Operation Amplifier Output
99		NC		Empty Pin
100	78	OP2P	I	The Positive Input of AC/DC Converter Operation Amplifier

8. Dice Pad Layout & Pad Coordinate

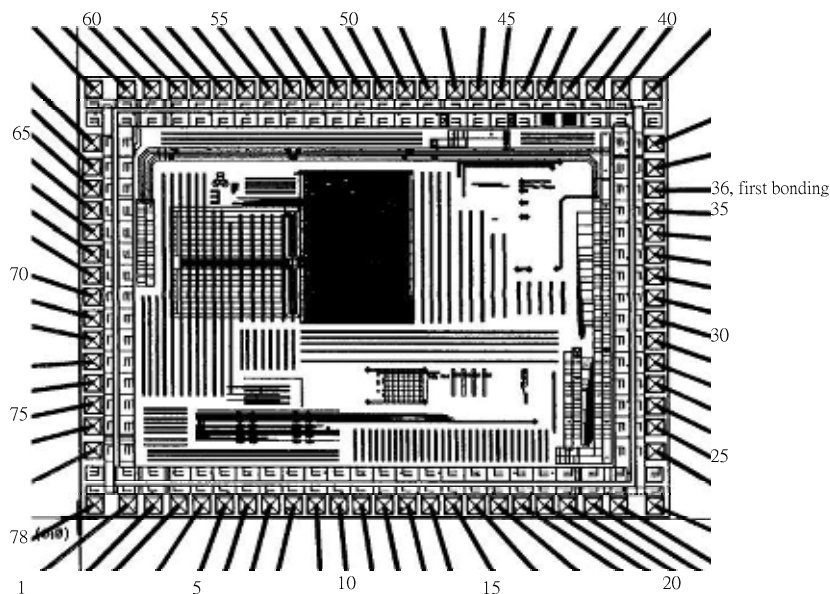

Substrate should be connected to VSS.

Pad opening: 90 μ m.

Chip size: 3.24mm \times 2.58mm.

Diagram 3 78PIN Dice

Pad No.	Name	X[mm]	Y[mm]	PadNo.	Name	X[mm]	Y[mm]
1	OP2N	0.264	0.077	40	CB	2.974	2.495
2	OP2O	0.404	0.077	41	CA	2.834	2.495
3	ADIP	0.544	0.077	42	VGG	2.694	2.495
4	ADIN	0.669	0.077	43	VDDA	2.569	2.495
5	SA	0.794	0.077	44	RLCD	2.444	2.495
6	SGND	0.919	0.077	45	XIN	2.319	2.495
7	ADP	1.044	0.077	46	XOUT	2.194	2.495
8	DT	1.169	0.077	47	TXD	2.069	2.495
9	SMV	1.294	0.077	48	SEG14	1.923	2.495
10	CRES1	1.419	0.077	49	SEG13	1.798	2.495
11	RL	1.544	0.077	50	SEG12	1.673	2.495
12	N.C	1.669	0.077	51	SEG11	1.548	2.495
13	RCAP	1.794	0.077	52	SEG10	1.423	2.495
14	ONEK	1.919	0.077	53	SEG9	1.298	2.495
15	TENK	2.044	0.077	54	SEG8	1.173	2.495
16	HUNK	2.169	0.077	55	SEG7	1.048	2.495



FS9721_LP3

4,000 counts auto range DMM IC.

17	ONEM	2.294	0.077	56	SEG6	0.923	2.495
18	TENM	2.419	0.077	57	SEG5	0.798	2.495
19	CRES2	2.544	0.077	58	SEG4	0.673	2.495
20	TSTB	2.669	0.077	59	SEG3	0.548	2.495
21	ADPC1	2.809	0.077	60	SEG2	0.408	2.495
22	ADPC2	2.949	0.077	61	SEG1	0.268	2.495
23	SELECT	3.147	0.077	62	COM1	0.091	2.495
24	RANGE	3.157	0.396	63	COM2	0.077	2.176
25	REL	3.157	0.536	64	COM3	0.077	2.036
26	HOLD	3.157	0.661	65	COM4	0.077	1.911
27	Hz/DUTY	3.157	0.786	66	ENTX	0.077	1.786
28	CAP	3.157	0.911	67	BEEPER	0.077	1.661
29	MEA4	3.157	1.036	68	BLOUT	0.077	1.536
30	MEA3	3.157	1.161	69	RST	0.077	1.411
31	MEA2	3.157	1.286	70	REFI	0.077	1.286
32	MEA1	3.157	1.411	71	REFO	0.077	1.161
33	LCDC1	3.157	1.536	72	FTA	0.077	1.036
34	LCDC2	3.157	1.661	73	FTB	0.077	0.911
35	TSTA	3.157	1.786	74	FTC	0.077	0.786
36	VSS	3.157	1.911	75	TSTC	0.077	0.661
37	AGND	3.157	2.036	76	OP1N	0.077	0.536
38	VDD	3.157	2.176	77	OP1O	0.077	0.396
39	VB	3.148	2.495	78	OP2P	0.083	0.077

9. Technical Specification (VDD=3V, Ta=25°C)

Symbol	Parameter	Test Condition	Min	Typ	Max	Units
VDD	Recommend Operation Power Voltage		2.4		3.6	V
IDD	Supply Current	At DCV Mode		1.5	2	mA
IPO	Power Supply Current	At Power Off			10	μA
VIH	Digital Input High Voltage		VDD-0.5			V
VIL	Digital Input Low Voltage				0.5	V
Ipu	Pull up Current	Vin=0		5	10	μA
AGND	Analog Ground Voltage		VDD/2 -3%	VDD/2	VDD/2 +3%	V
VDDA	Analog Power		3.4	3.7	4	V
VBAND	Build in Reference Voltage	Relative AGND	1.1	1.25	1.4	V
	Build in Reference Voltage Output Voltage Coefficient	VDD=2.4V~3.6V	-2000		+2000	ppm/V
REFI	Recommend Reference input Voltage	Relative AGND		0.44		V
VBATT	Low Battery Detector Voltage		2.25	2.4	2.55	V
FLCD	LCD Frame Frequency			32		Hz
VLCD	LCD Pk-Pk Driver Voltage		2.8	3	3.2	V



FS9721_LP3

4,000 counts auto range DMM IC.

FBEEP	Beeper Frequency			2.7		kHz
FRS232	RS232 Baud Rate			2400		bit
IRSOUT	RS232 Output High Current	VOH=2V	2			mA
	Zero Input Reading	DC ADPx1 Input=0V	-0.001	0.000	0.001	
	Linearity (Max. Deviation From Best Straight Line Fit)	DC ADPx1 · Input, Full Scale±240.0mV	-1	0	+1	Counts
	AC Measurement Bandwidth Error	AC ADPx1 Input240mVrms 20Hz~1kHz			0.2	%
Rcc	Continuity Check Value		10		60	Ohm
	ADC Measurement O.L Display Count			4050		Counts
	Autorange Up Counts			4000		Counts
	Autorange Down Counts			360		Counts
VFREA	Frequency Counter Input Level (Hz/Duty Control)	VIL(Relative to AGND)	-60			mV
		VIH(Relative to AGND)			60	mV
FMAXA	Frequency Counter Max Input frequency (Hz/Duty Control)	Vpp= ± 100mV Square Wave Input	500k			Hz
*1	Duty Measurement Min Pulse Width Error (Hz/Duty Control)	Vpp= ± 100mV Square Wave Input			1	µS
VFRED	Frequency Counter Input Level (MEAS=0101)	VIL(Relative to AGND)	-600			mV
		VIH(Relative to AGND)			600	mV
FMAXD	Frequency Counter Input Level (MEAS=0101)	Vpp= ± 600mV Square Wave Input	5M			Hz
*1	Duty Measurement Min Pulse Width Error(MEAS=0101)	Vpp= ± 600mV Square Wave Input			100	nS
	Capacitor Measurement Accuracy after Zero Input Relative. To adjust with 512.0nF Mode Standard	51.20 nF Mode			2%+10	Counts
		512.0 nF Mode			0.5%+3	Counts
		5.120 µF Mode			1%+2	Counts
		51.20 µF Mode			1.5%+2	Counts

*1 If input square wave during duty cycle measurement, then the deviation is mainly from the analyzable pulse width of the comparator itself. If the value is an input 100kHz square wave, we can divide the square wave into 1000 parts (1000Counts), and each part is 10nS. Therefore the largest deviation in duty cycle measurement is (100nS/10nS)=10Counts. The output 50.0% signal may be measured 50.0%±1.0%, and the signal that larger than 99% or smaller than 1% may not be measured, then it will display 0.00%.

10.Measurement Mode Select

10.1 Measurement Mode Select (MEA1~MEA4: Open is “1”; Connect to VSS is “0”)

MEA4	MEA3	MEA2	MEA1	Measurement Function and SELECT Key Function Switch	Hz/Duty	Rel	Hold	Range	Select	Jumper ①
1	1	1	1	DCV/ACV②	DCV/ACV Switch	V/Hz/Duty Switch	●	●	●	J4
1	1	0	1	Ohm/Diode/Cont./Cap	CAP=1:Ohm/Diode/Cont. Switch CAP=0:Ohm/Diode/Cont./Cap Switch		●	●	Ohm●	J3, J5
1	0	1	0	DCV No mV Mode		V/ Hz/Duty Switch	●	●	●	J4
1	0	0	1	ACV②		V/ Hz/Duty Switch	●	●	●	J4
1	0	1	1	DCmV		V/Hz/Duty Switch	●	●		J3
1	0	0	0	10A③	DCA/ACA Switch	A/Hz/Duty Switch	●	●	●	J2
1	1	1	0	mA③	DCmA/ACmA Switch	mA/Hz/Duty Switch	●	●	●	J2, J9
1	1	0	0	μA③	DC μA/AC μA Switch	μA/ Hz/Duty Switch	●	●	●	J2, J10
0	1	1	1	Cap			●	●		J3, J5
0	1	0	1	Hz/Duty④		Hz/Duty Switch		●		J6, J8
0	0	1	1	Input from ADP Refer to table 10.2						
0	0	1	0							
0	0	0	1							
0	0	0	0							
0	1	1	0	Input from ADP ⑤						
0	1	0	0	ACA 400.A/4000A						

Notes: ① In “Jumper” column, JX means the JX of the measurement is connected in the common use circuitry of Diagram 6 and Diagram 7.

② In auto mode, it has to press Range key for ACV mode to select ACmv measurement.

③ TSTB=1, the current is input with 400mV/4V; TSTB=0, the current is input with 40mV/400mV. For details, please refer to “15.13 Current Measurement”.

④ The Mode is to input measuring Hz/Duty with ADP path.

⑤ ADP can input 400.0mV/40.00mV, autoranging, display 4000, 400.0.

10.2 ADP Input and Self-defined Symbol and Decimal Location (MEA1~MEA4: Open is “1”; Connect to VSS is “0”)

MEA4	MEA3	MEA2	MEA1	Range of Input Voltage	Input Channel	Decimal Location	Symbol Location	Symbol
0	0	1	1	±400mV	ADP	4000	Decided by LCDC1 and LCDC2	Users Self-defined
0	0	1	0			400.0		
0	0	0	1			40.00		
0	0	0	0			4.000		



FS9721_LP3

4,000 counts auto range DMM IC.

10.3 Located Self-defined Symbol in LCD by the assembly of LCDC1 and LCDC2

LCDC1	LCDC2	Symbol Location	Description
0	0	COM1 , SEG14	LCDC1 and LCDC2: Open is "1"; Connect to VSS is "0"
1	0	COM2 , SEG14	
0	1	COM3 , SEG14	
1	1	COM4 , SEG14	

10.4 The Function of ADPC1 and ADPC2 in ADP Input (ADPC1 and ADPC2: Open is "1"; Connect to VSS is "0")

ADPC1	ADPC2	DC/AC Status	ADP Max. Input Voltage
1	1	DC	400mV
1	0	AC	
0	1	DC	40mV
0	0	AC	

11.Keys Definition

11.1 Range (Auto/Manual Measurement Switch)

Range key is the auto/manual measurement key that acts with trigger. Power-on default is auto measurement, and press one time to switch to the manual measurement. In manual measurement mode, the system will jump up one mode for each press until the highest mode, then return to the lowest mode as a loop. If press the key over 2 seconds, the system will switch back to auto measurement status. Frequency and capacitance measurement cannot use manual measurement.

11.2 Hold/BLCTR (Reading Hold/Backlight Control)

Hold/BLCTR key is the reading hold /backlight control key that acts with trigger. The function is to hold the display of reading/backlight control. To press the key, the display value will be locked and keep unchanged. To press the key again, the locked status will be erased and enter the normal measurement status. When press and hold the key over 2 seconds, the backlight will be on. In the backlight on status, press the key over 2 seconds, the backlight will be off.

11.3 Rel (Relative Value Measurement)

Rel key is the relative value measurement key that acts with trigger. Except Hz/Duty, Diode and Continuity, other functions can do the relative value measurement.

11.4 Select (Function Switch)

Select is the function select key that acts with trigger. Use the key as measuring functions select.

11.5 RS232 (Serial Output Control)

RS232 is the serial output control key that acts with lock. When the key is close, LCD displays RS232 symbol that means the meter enters the data transmission status, and is able to transfer the data out; when the key is open, it will exit and the data transmission status will stop.

11.6 Hz/Duty (Frequency/Duty Cycle)

Hz/Duty is the Frequency/Duty Cycle select key that acts with trigger. In frequency measurement mode, press the key can select frequency or duty cycle measurement mode; in AC/DC voltage or AC/DC current mode, press the key can proceed to Voltage/Frequency/Duty Cycle or Current/Frequency/Duty Cycle measurement mode select.



11.7 Reset (Reset key)

Reset is the reset key that acts with trigger. Press the key to make the microprocessor to reset.

12. Other Functions

12.1 Auto Power Off

In the process of measuring, no matter the function key or switch, if there is no any action on them within 30 minutes, the meter will be “Auto Power Off” (Standby Mode). In auto power off status to press the function key or switch, the meter will be “Auto Power On” (Operating Mode). To press and hold the “SELECT” key to turn the system on, the auto power off function will be cancelled.

In RS232 operation mode, the auto power off function will be cancelled.

12.2 Buzzer

When press any key or turn any function switch, the buzzer will raise one sound (approx. 0.25 second ~1 second). When doing the open-short test, if the resistance is smaller than 50Ω , the buzzer will sound.

12.3 Backlight

The system has the backlight driver output to control the on and off of the backlight circuit. It provides the convenience to read in a dim light and worse vision. If press the Hold/BLCTR key over approx. 2 seconds, the backlight will be on, and to press the key again over 2 seconds, the backlight will be off.

12.4 Serial Data Output

The system has the serial data output function. When the meter is connected with the equipment that has serial input interface (RS232) such as computer, it can output the measuring data for recording, analyzing, processing and printing the measuring results.

13. RS232 Transmission Protocol

13.1 Direction: One-way to computer.

13.2 Serial Transfer Rate: 2400 bps

13.3 Data Bit: 8 bit.

13.4 Odd and Even Calibration: No

13.5 Data Decimal: Hex

13.6 Data Length: 14 Bytes.

13.7 Data Information: LCD table on-off information.

13.8 Data Format: 1st byte → 1X (X is seg1, 4 bits represent the data on the LCD table)
 2nd byte → 2X (X is seg2, 4 bits represent the data on the LCD table)
 3rd byte → 3X (X is seg3, 4 bits represent the data on the LCD table)
 and so on
 1X → 4 bit , 2X → 4 bit , 3X → 4 bit

 EXH → 4it

13.9 X means: Bit3 ~ Bit 0 → segn (COM4—COM1)

13.10 Sampling Rate: 40KHz

13.11 ADC Output Frequency: 40Hz

13.12 ADC Output Frequency After Average: 10Hz

13.13 Output Frequency After Auto-Zero: 4Hz



FS9721_LP3

4,000 counts auto range DMM IC.

14.LCD Display -- FS9721_LP3(C2=LCDC2, C1=LCDC1)

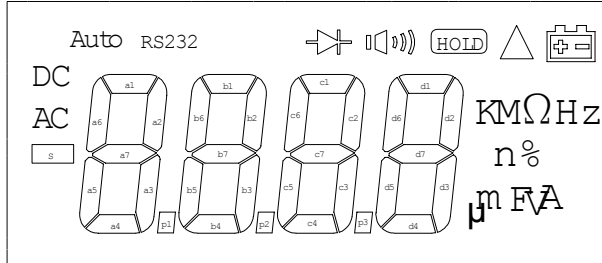

9711_LP3 LCD DISPLAY AND FORMAT

PIN COM	1 COM4	2 COM3	3 COM2	4 COM1	5 SEG1	6 SEG2	7 SEG3	8 SEG4	9 SEG5	10 SEG6	11 SEG7	12 SEG8	13 SEG9	14 SEG10	15 SEG11	16 SEG12	17 SEG13	18 SEG14
COM1				COM1	RS232	a1	a2	b1	b2	c1	c2	d1	d2			HOLD		C2_G1 = 0_0
COM2			COM2	Auto	a6	a7	b6	b7	c6	c7	d6	d7	K	M		Hz		C2_G1 = 0_1
COM3		COM3		DC	a5	a3	b5	b3	c5	c3	d5	d3	n	%	Ω	V		C2_G1 = 1_0
COM4	COM4			AC		a4	p1	b4	p2	c4	p3	d4	μ	m	F	A		C2_G1 = 1_1

- Notes: 1. Working Voltage: 3V.
2. Drive Method: 1/4 Duty, 1/3 Bias.

Diagram 4 LCD Display Structure

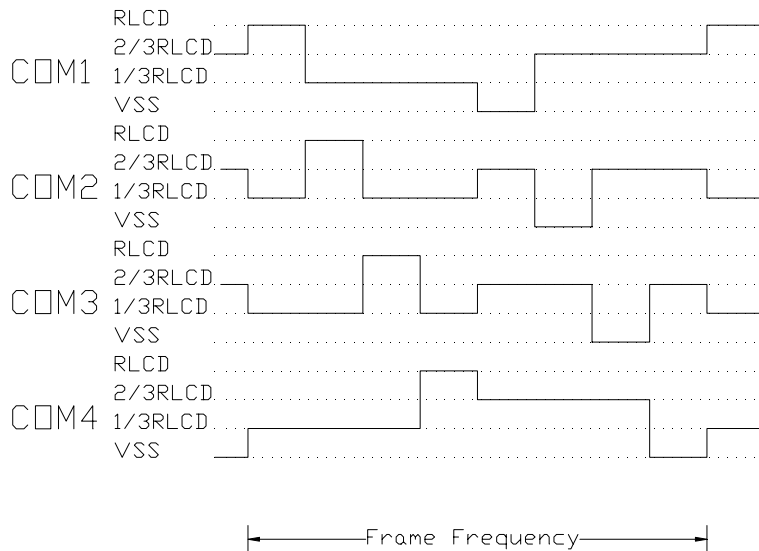

Diagram 5 LCD Display COM Driver Waveform



FS9721_LP3

4,000 counts auto range DMM IC.

15. Application Description

15.1 Common Use Circuitry A · 100 Pin Package IC

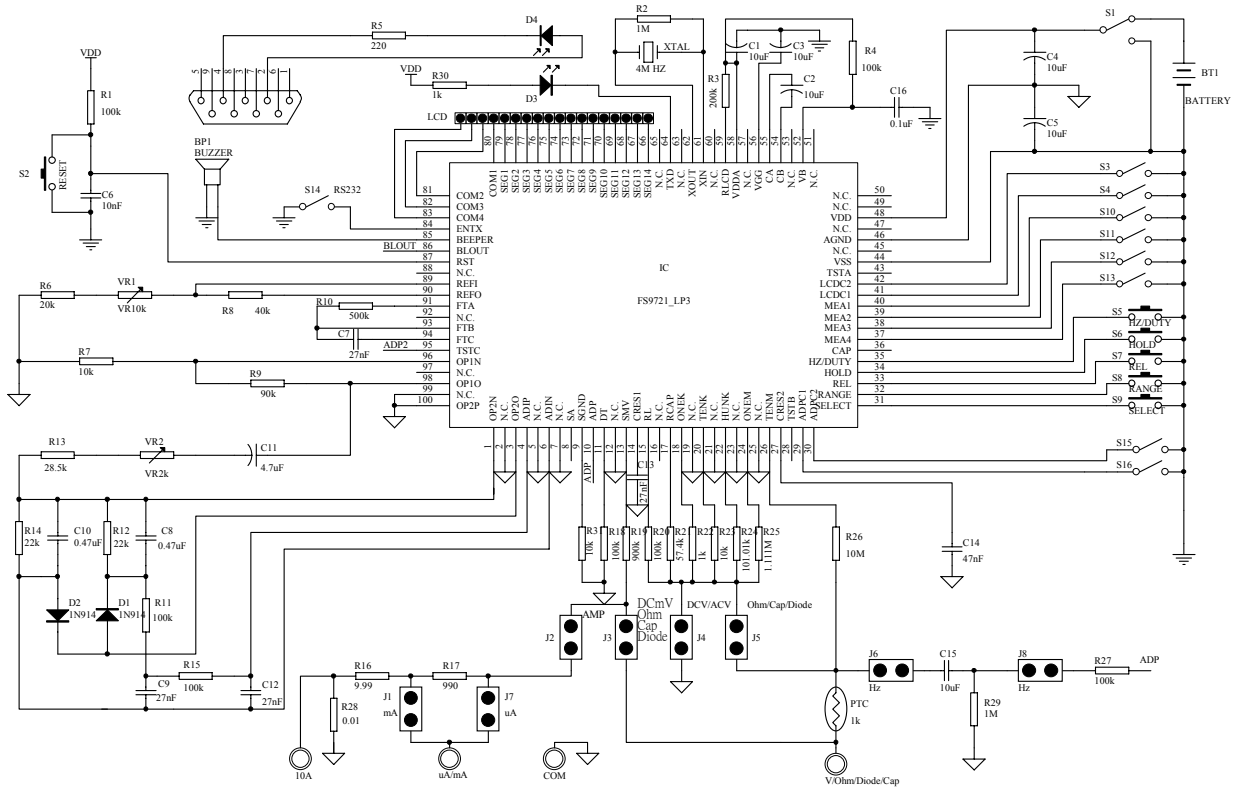

- VSS Battery Negative Terminal and IC Negative Power Input
- VDD Battery Positive Terminal and IC Positive Power Input
- VGG VDD Charge Pump voltage about 2*VDD
- VDDA IC Analog Power about 3.9V
- AGND Analog Common about VDD/2

Diagram 6 100 PIN Common Use Circuitry



FS9721_LP3

4,000 counts auto range DMM IC.

B · 78 Pin Dice IC

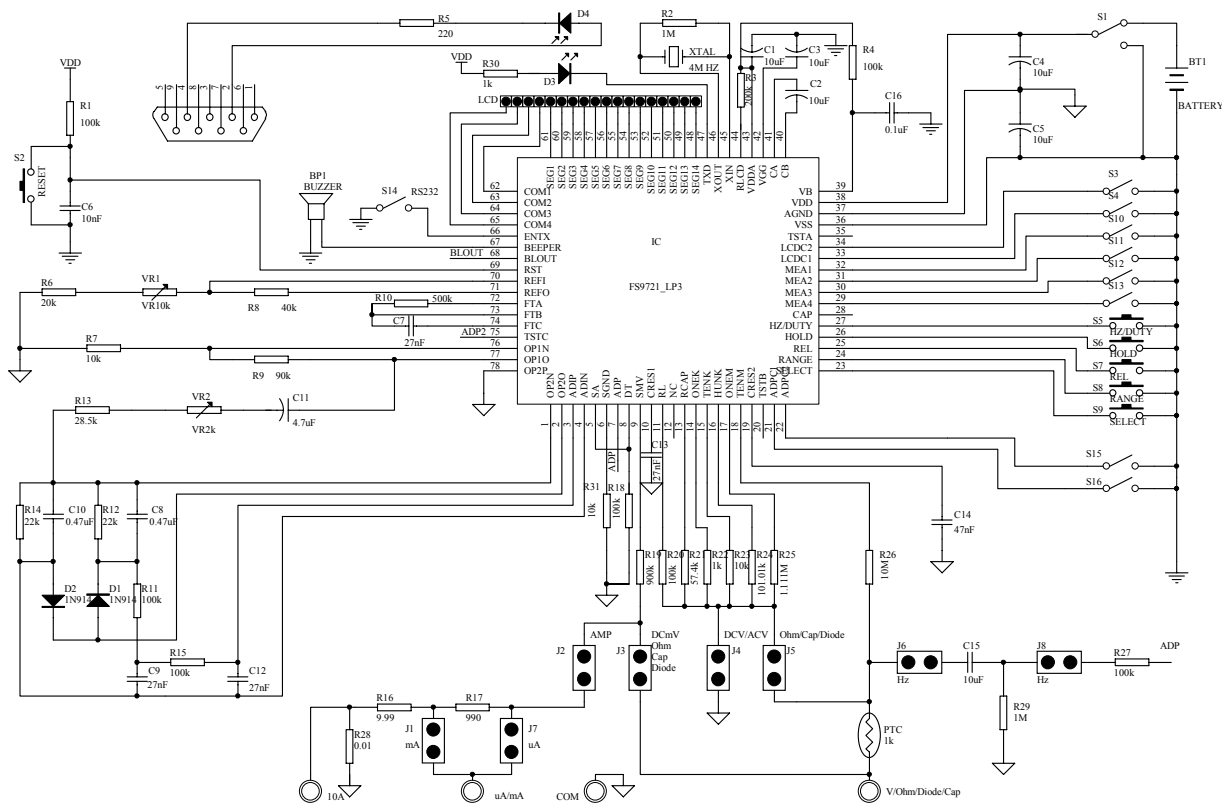

- VSS Battery Negative Terminal and IC Negative Power Input
- VDD Battery Positive Terminal and IC Positive Power Input
- VGG VDD Charge Pump voltage about 2*VDD
- VDDA IC Analog Power about 3.9V
- AGND Analog Common about VDD/2

Diagram 7 78 PIN Common Use Circuitry

15.2 FS9721_LP3 Technical Description and the Relationship of its Components

	Network	Current Mode /10 (R19:R18=9:1) TSTB Open	Current Mode ×10 (R9:R7=9:1) TSTB connect to VSS	AC Measurement R13+VR2 R12=R14	Voltage Reference (R8,R6, VR1)
DC 400mV	R26	No	No	No	Yes
DC 4V	$R25/(R26+R25)=1/10$	No	No	No	Yes
DC 40V	$R24/(R26+R24)=1/100$	No	No	No	Yes
DC 400V	$R23/(R26+R23)=1/1000$	No	No	No	Yes
DC 1000V	$R22/(R26+R22)=1/10000$	No	No	No	Yes
AC 400mV	$R25/(R26+R25)=1/10,$ R9:R7=9:1	No	No	Yes	Yes
AC 4V	$R25/(R26+R25)=1/10$	No	No	Yes	Yes
AC 40V	$R24/(R26+R24)=1/100$	No	No	Yes	Yes
AC 400V	$R23/(R26+R23)=1/1000$	No	No	Yes	Yes
AC 1000V	$R22/(R26+R22)=1/10000$	No	No	Yes	Yes
R 400Ω	$R26//R22=1k\Omega$	No	No	No	No
R 4kΩ	$R26//R22=1k\Omega$	No	No	No	No
R 40kΩ	$R26//R23=10k\Omega$	No	No	No	No
R 400kΩ	$R26//R24=100k\Omega$	No	No	No	No
R 4MΩ	$R26//R25=1M\Omega$	No	No	No	No
R 40MΩ	$R26=10M\Omega$	No	No	No	No
DC 400 μA	$R17+R16+R28=1k\Omega (100\Omega)$	No	Yes	No	Yes
DC 4000 μA	$R17+R16+R28=1k\Omega (100\Omega)$	Yes	No	No	Yes
DC 40mA	$R16+R28=10\Omega (1\Omega)$	No	Yes	No	Yes
DC 400mA	$R16+R28=10\Omega (1\Omega)$	Yes	No	No	Yes
DC 10A	$R28=0.01\Omega$	No	Yes	No	Yes
AC 400 μA	$R17+R16+R28=1k\Omega (100\Omega)$	No	Yes	Yes	Yes
AC 4000 μA	$R17+R16+R28=1k\Omega (100\Omega)$	Yes	No	Yes	Yes
AC 40mA	$R16+R28=10\Omega (1\Omega)$	No	Yes	Yes	Yes
AC 400mA	$R16+R28=10\Omega (1\Omega)$	Yes	No	Yes	Yes
AC 10A	$R28=0.01\Omega$	No	Yes	Yes	Yes
CAP	R21	No	No	No	No
Diode		No	No	No	Yes

15.3 FS9721_LP3 (Diagram 6, Diagram 7) Components List

No.	Spec.	No.	Spec.	No.	Spec.	No.	Spec.	No.	Spec.
R1	100kΩ	R13	28.5kΩ	R25	1.111MΩ	C7	27nF	D3	Send
R2	1MΩ	R14	22kΩ	R26	10.000MΩ	C8	0.47μF	D4	Receive
R3	200kΩ	R15	100kΩ	R27	100kΩ	C9	27nF	VR1	10kΩ
R4	100kΩ	R16	9.99Ω	R28	0.01Ω	C10	0.47μF	VR2	2kΩ
R5	220Ω	R17	990Ω	R29	1MΩ	C11	4.7nF	LCD	LCD
R6	20kΩ	R18	100kΩ	R30	1kΩ	C12	27nF	XTAL	4MHz
R7	10kΩ	R19	900kΩ	C1	10 μF	C13	27nF	IC	FS9721_LP3
R8	40kΩ	R20	100kΩ	C2	10 μF	C14	47nF	Battery	1.5V×2
R9	90kΩ	R21	57.4kΩ	C3	10 μF	C15	10μF	BP1	Buzzer
R10	500kΩ	R22	1.001kΩ	C4	10 μF	C16	0.1μF	PTC	1kΩ
R11	100kΩ	R23	10.010kΩ	C5	10 μF	D1	1N914		
R12	22kΩ	R24	101.010kΩ	C6	10nF	D2	1N914		

Note: The technical instructions such as the accuracy, duty and press-proof of resistance and capacitance components are not marked in the common use circuitry and the components list, they depends on users' actual needs when designing the products.

15.4 Power System

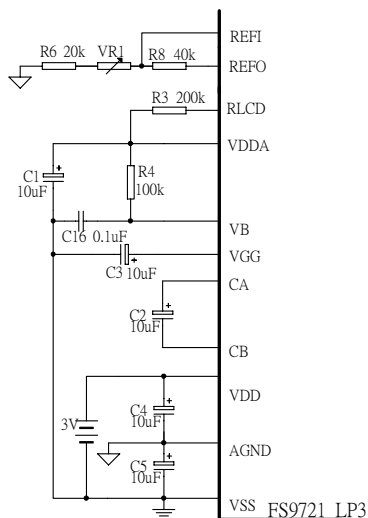

Diagram 8 Power Circuit

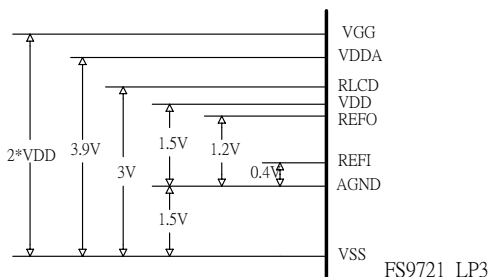

Diagram 9 Relative Voltage for Each Point

VB is the IC internal bias current input. The increase of R4 will decrease IC internal current consumption, but insufficient bias current will influence AC measurement input range.

AGND is the analog ground connection. Its potential is equal to the middle point of battery voltage. The potential of the point is generated by IC internal voltage that cannot connect to the middle point of battery.

C4 and C5 are the bypass capacitances in one hand, and in the other hand to make AGND be regulated to VDD and VSS. C2 is power pump capacitance. IC makes VDD go through C2 to charge/discharge so as to raise VGG up to approximate double.



FS9721_LP3

4,000 counts auto range DMM IC.

VDDA is the output voltage after regulating VGG in the IC that is about 3.9V relative to VSS.

REFO is the IC internal bandgap power that is about 1.2V relative to AGND, and has the stability of 100ppm/°C.

15.5 Power Supply Circuit

According to different application of users, the supply methods are different. In some measurements, all operating amplifier, Hale components and so on sensors require larger voltage so that it is difficult to supply by 3V. If so, the following supply methods are recommended:

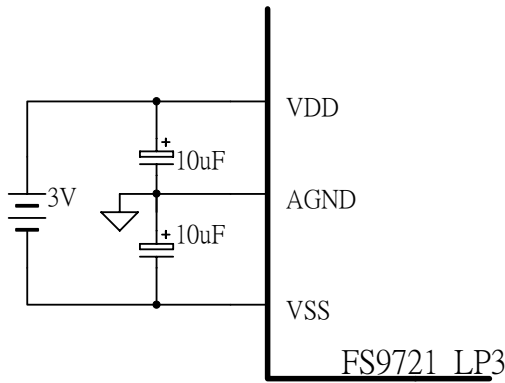

Diagram 10 3V Power Supply

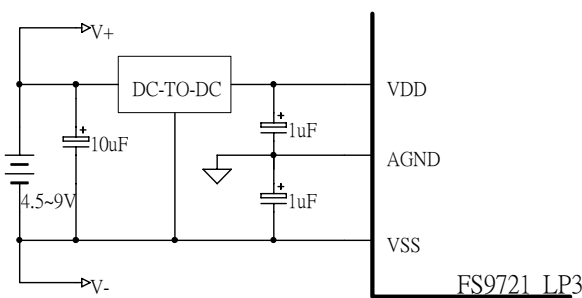

Diagram 11 4.5V~9V Power Supply

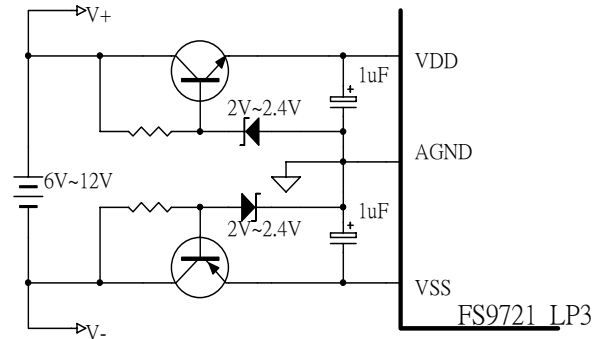

Diagram 12 6V~12V Power Supply

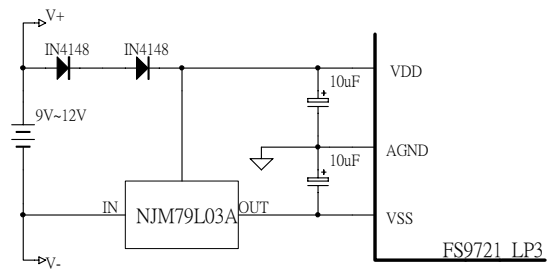

Diagram 13 9V~12V Power Supply

15.6 Base Power

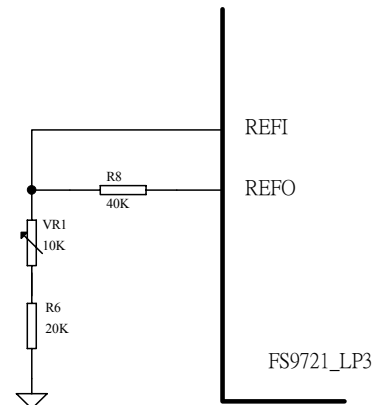

Diagram 14 Utility of Internal Base Power

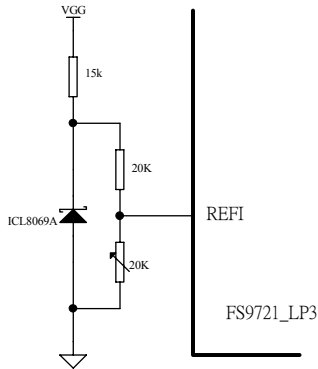

Diagram 15 Utility of External Base Power

15.7 Trigger Reset Circuit

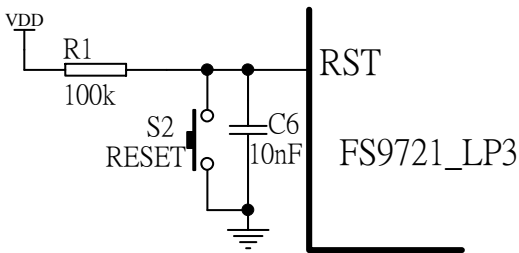

Diagram 16 Reset Circuit

15.8 Quartz Oscillation Circuit

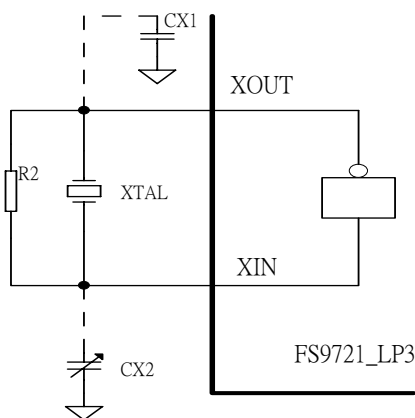

Diagram 17 Quartz Oscillation Circuit

In the diagram, R2 is the reviser to offer the statical working point, CX2 is the frequency fine adjustment, and CX1 is the temperature offset. In the unexacting situation, CX1 and CX2 can be unused.

15.9 Buzzer Driver Circuit

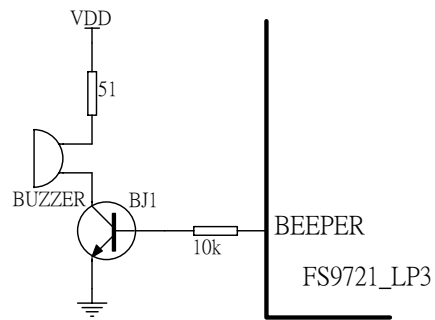

Diagram 18 Low Resistance Buzzer Connection

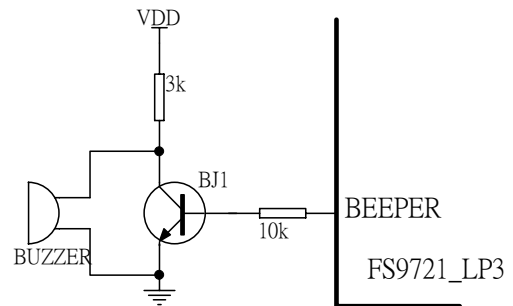

Diagram 19 High Resistance Buzzer Connection

15.10 Mode Switch and Function Control Circuit

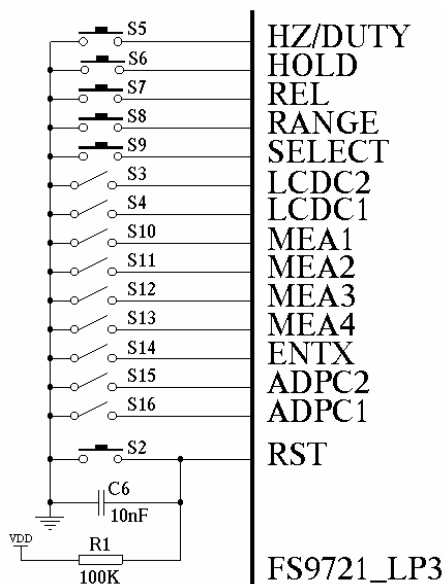

Diagram 20 Mode Switch and Function Control Circuit

S3~S4, S10~S13 and S15~S16 are the mode switches. For the functions of S3~S4, please refer to 10.3. For the functions of S15~S16, please refer to 10.4. For the functions of S10~S13, please refer to 10.1. S14 is RS232 output control switch. S2 and S5~S9 are the function select switches which are the trigger switches. For their functions, please refer to “Keys Definition” and “Other Functions”.

In practice application, to use which switches or keys depend on the actual situation.

15.11 AC Rectifier Circuit

Diagram 21 is FS9721_LP3 average rectification circuitry. In the circuitry, AC signals enters IC through R26, then divided the voltage by R26, R25, R24, R23 and R22. After voltage division, the AC signals come out from OP10 pin, and enter the IC via AD IP pin and ADIN pin after rectifying. VR2 can adjust the size of the signal to be the calibration of AC measurement.

400mV mode is amplified 10 times by OP.

Diagram 22 is the peak value rectification circuitry. Diagram 23 is the true valid value rectification circuitry. User can decide which rectification circuitry to use according to the demand of oneself.

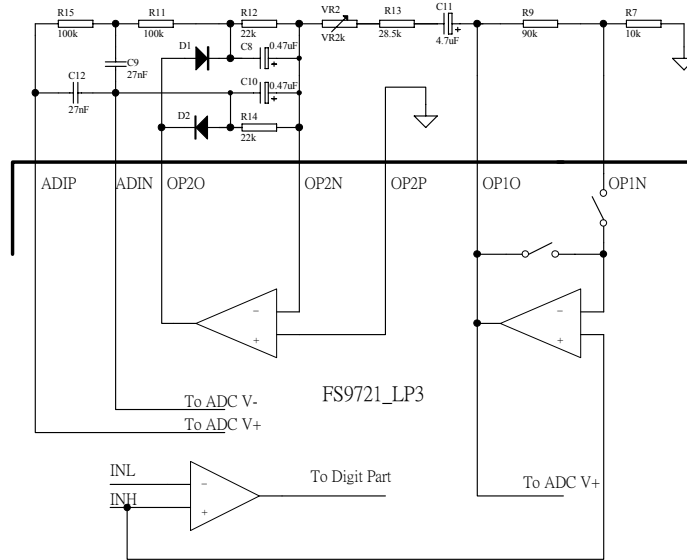

Diagram 21 Average Rectification Circuitry

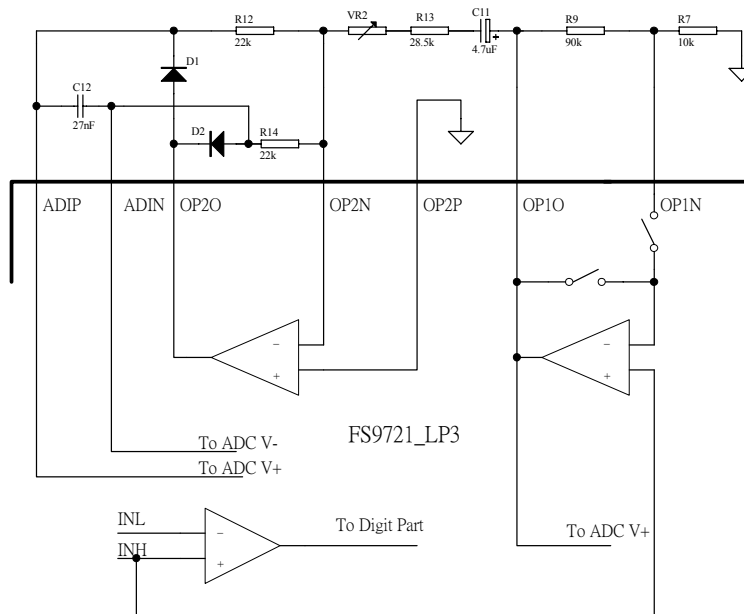

Diagram 22 Peak Rectification Circuitry

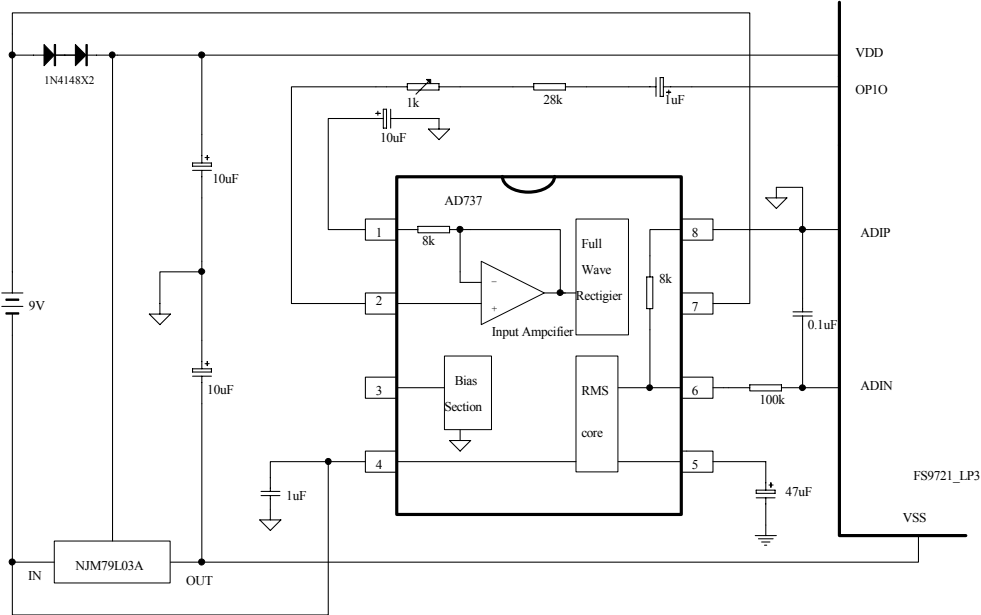

Diagram 23 True Valid Value Rectification Circuitry

15.12 Voltage Measurement

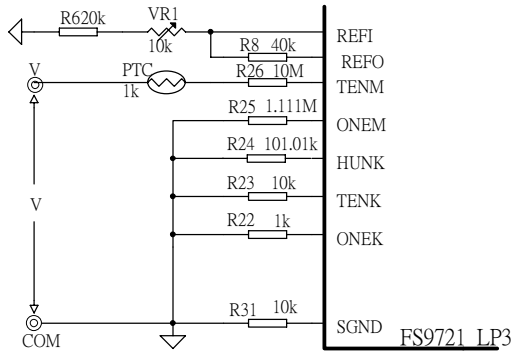

Diagram 24 Voltage Measurement

When doing the voltage measurement, the measuring voltage is input from resistance R26 and DCmV is not divided but enter IC directly; the voltages of 4V, 40V, 400V, 1000V modes are divided by R25, R24, R23, R22 and R26 to gain 1/10, 1/100, 1/1000, 1/10000 input voltages, then enter IC. To adjust the resistance value of VR1 can do the calibration of the measurement.

The voltage division diagram of voltage measurement is as below:

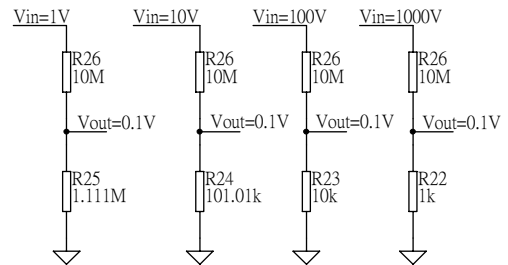

Diagram 25 Voltage Division Circuitry

The formula of voltage division is:

$$V_{out} = V_{in} \times \left[\frac{R_s}{R_26 + R_s} \right]$$

Rs is R25, R24, R23 or R22.

Therefore, the accuracy of R22, R23, R24, R25 and R26 decides the accuracy of the measurement.

ACmV Voltage enters IC through R26 and is divided by R25 and R26 to get 1/10 voltage, then is amplified 10 times to fulfill the measurement, so the accuracy of R9 and R7 also determines the measuring accuracy of ACmV voltage.

15.13 Current Measurement

The difference between Current Measurement (A) and Current Measurement (B) is as follow:

Mode	Current Measurement (A)		Current Measurement (B)	
	TSTB Open		TSTB connects to VSS	
	Measurement	Sampling Resistance	Measurement	Sampling Resistance
A	10A	0.01 Ω	10A 4A	0.01 Ω
mA	400mA 40mA	10 Ω	400mA 40mA	1 Ω
μ A	4000 μ A 400 μ A	1k Ω	4000 μ A 400 μ A	100 Ω
Max. Voltage Reduction	4V		0.4V	

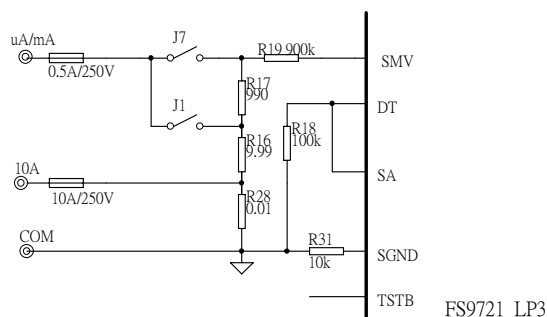

Diagram 26 Current Measurement (A)

In TSTB open mode, the current signal enters IC from R19.

When doing the current measurement, The sampling resistance of μ A mode is R16+R17+R28, the sampling resistance of mA mode is R16+R28, and the sampling resistance of 10A mode is R28. They are measured respectively through the mode switch. When measuring μ A, J1 is open and J7 is close; when measuring mA, J7 is open and J1 is close; the large current enters directly via 10A port.

The maximum reduced voltage for μ A, mA and 10A modes is 4V. These voltages are input voltage comparator to compare. If the voltage is smaller than 400mV, it will be sent to $\times 10$ times amplifier to amplify, then sent to A/D converter; if the voltage is larger than 400mV, the system will work the auto-ranging signal, and jump up one mode under the control of microprocessor and send the current signal directly to the A/D converter.

The accuracy of resistance R16, R17, R28, R18 and R19 affects the accuracy of the current measurement.

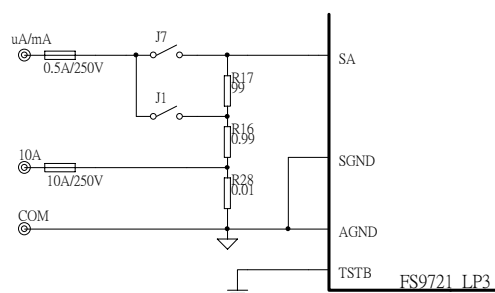

Diagram 27 Current Measurement (B)

In TSTB connecting to VSS mode, the current signal enters IC from SA.

When doing the current measurement, The sampling resistance of μ A mode is R16+R17+R28, the sampling resistance of mA mode is R16+R28, and the sampling resistance of 10A mode is R28. They are measured respectively through the mode switch. When measuring μ A, J1 is open and J7 is close; when measuring mA, J7 is open and J1 is close; the large current enters directly via 10A port.

The maximum reduced voltage for μ A, mA and 10A modes is 4V.

These voltages are input voltage comparator to compare. If the voltage is smaller than 40mV, it will be sent to $\times 10$ times amplifier to amplify, then sent to A/D converter; if the voltage is larger than 40mV, the system will work the auto-ranging signal, and jump up one mode under the control of microprocessor and send the current signal directly to the A/D converter.

The accuracy of resistance R16, R17, R28, R7 and R19 affects the accuracy of the current measurement.

15.14 Resistance Measurement

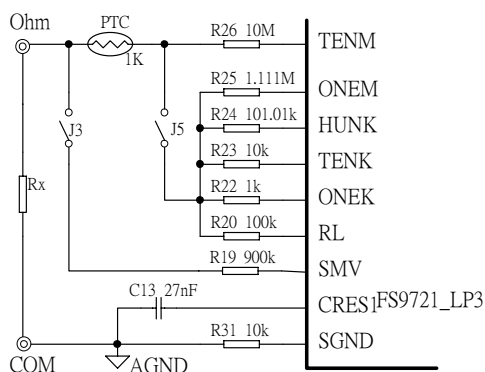

Diagram 28 Resistance Measurement

Resistance measurement refers to the standard resistance, and then takes a comparison between measuring resistance and standard resistance to get the measuring resistance value. The standard resistance of 40M Ω mode is 10M Ω (R26). The standard resistance of other modes are R26 to parallel respectively with R25, R24, R23 and R22 to get 1M Ω , 100k Ω , 10k Ω , 1k Ω resistance. When doing resistance measurement, internal IC will generate 0.4V voltage (relative to AGND), and the voltage is output respectively through resistance R26, R25, R24, R23 and R22 to the measuring resistance to do the comparing measurement.

R20 connects to RL, which is the negative input of the voltage reference that is gotten by the standard resistance.

J3 and J5 are mode switches. When doing resistance measurement, J3 and J5 are close.

C13 is the wave filter capacitance of measuring point in resistance measurement.

15.15 Diode Test

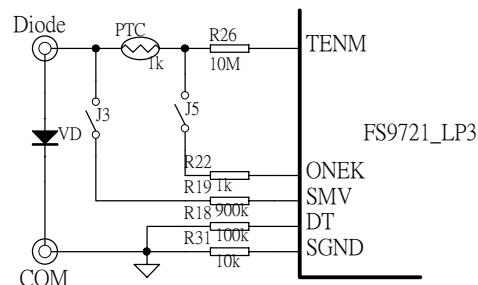

Diagram 29 Diode Measurement

Diode test generates 1.5V voltage from internal IC and outputs it through R22, then adds it to the positive of diode through PTC. The positive voltage reduction VD generated by diode is approx. 0.5V-0.7V. VD is divided by R20 and R19 to be 1/10 VD, then is amplified 10 times by internal OP and is delivered to A/D before displaying the VD value. J3 and J5 are mode switches. When doing diode measurement, J3 and J5 are close.

15.16 Open-Short Test

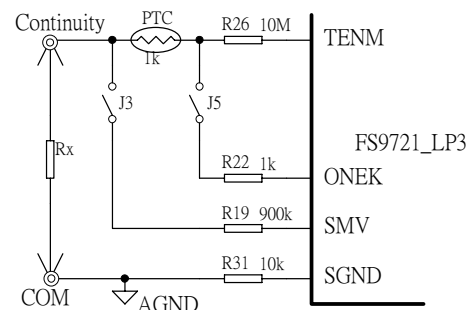

Diagram 30 Open-Short Tests

Open-Short Test is proceeded in 400 Ω resistance mode. 0.4V voltage (relative to AGND) is generated by internal IC and is output through R22, then is added to open-short measuring point through PTC. J3 and J5 are mode switches that are close during doing the open-short test. Rx gets voltage V_{RX} , and enters IC through R19. If Rx is smaller than 50 Ω , the buzzer will sound.



FS9721_LP3

4,000 counts auto range DMM IC.

15.17 Capacitance Measurement

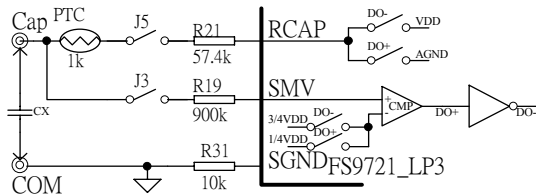

15.18 Frequency Measurement

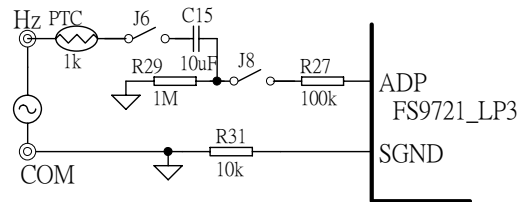

Input Typical Waveforms

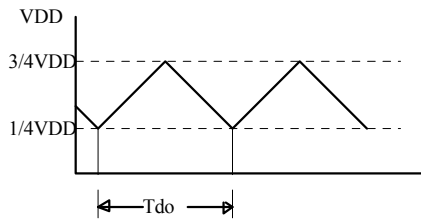

Diagram 32 Frequency Measurement

Diagram 31 Capacitance Measurement

Capacitance measurement is to charge/discharge the measuring capacitance through R21 to form an oscillation, then calculate the cycle of oscillation to get the capacitance value. To adjust R21 can calibrate the value in capacitance measurement. J3 and J5 are mode switches. When doing capacitance measurement, J3 and J5 are close.

16.Package Outline

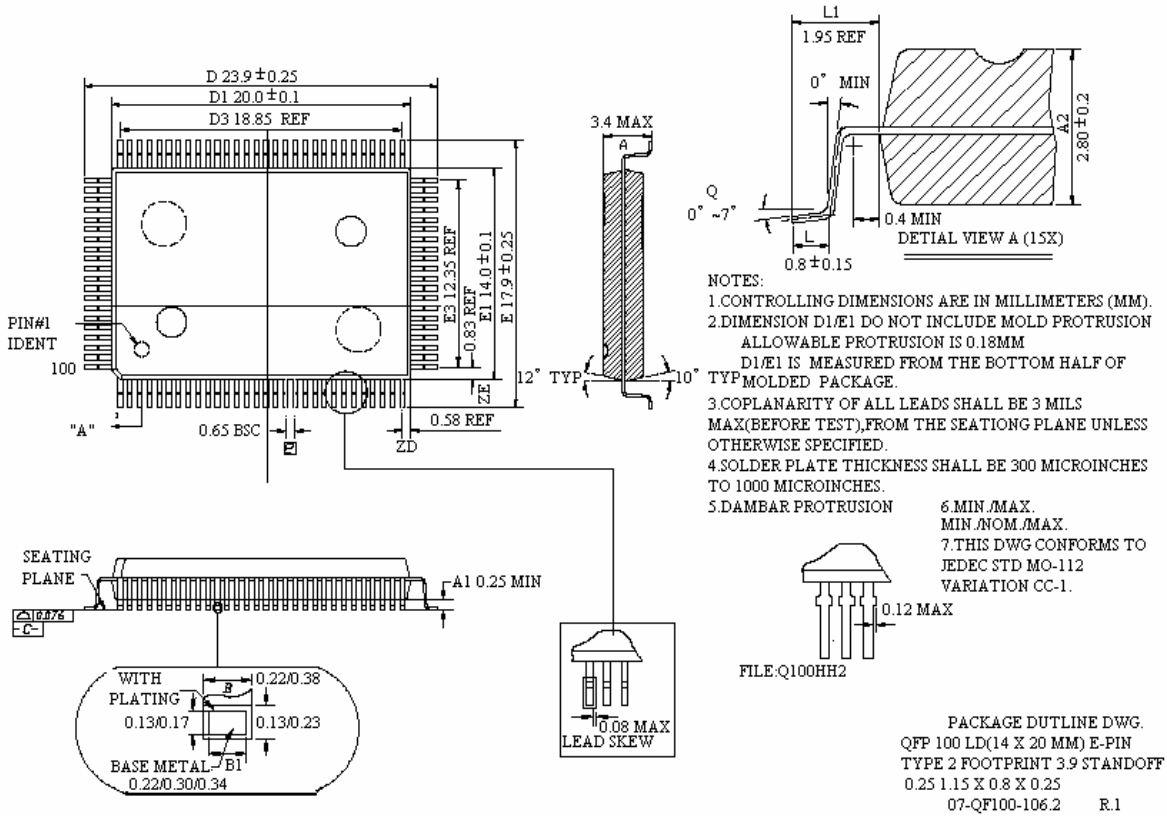

Diagram 33 Package Outline



FS9721_LP3

4,000 counts auto range DMM IC.

17. Demo Board

17.1 Demo Board Schematic

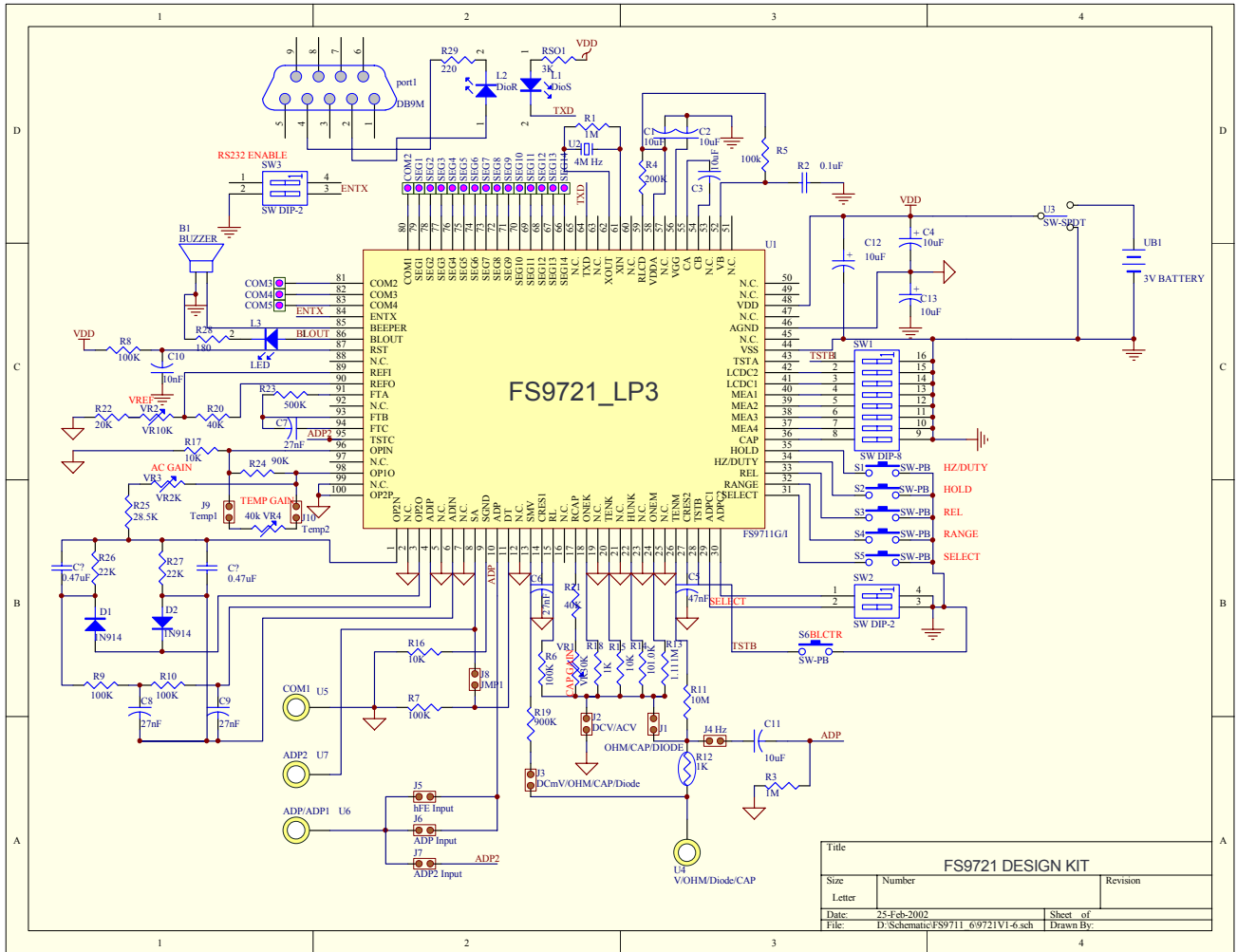

Diagram 34 Demo Board Schematic



FS9721_LP3

4,000 counts auto range DMM IC.

17.2 FS9721_LPX Demo Board Location

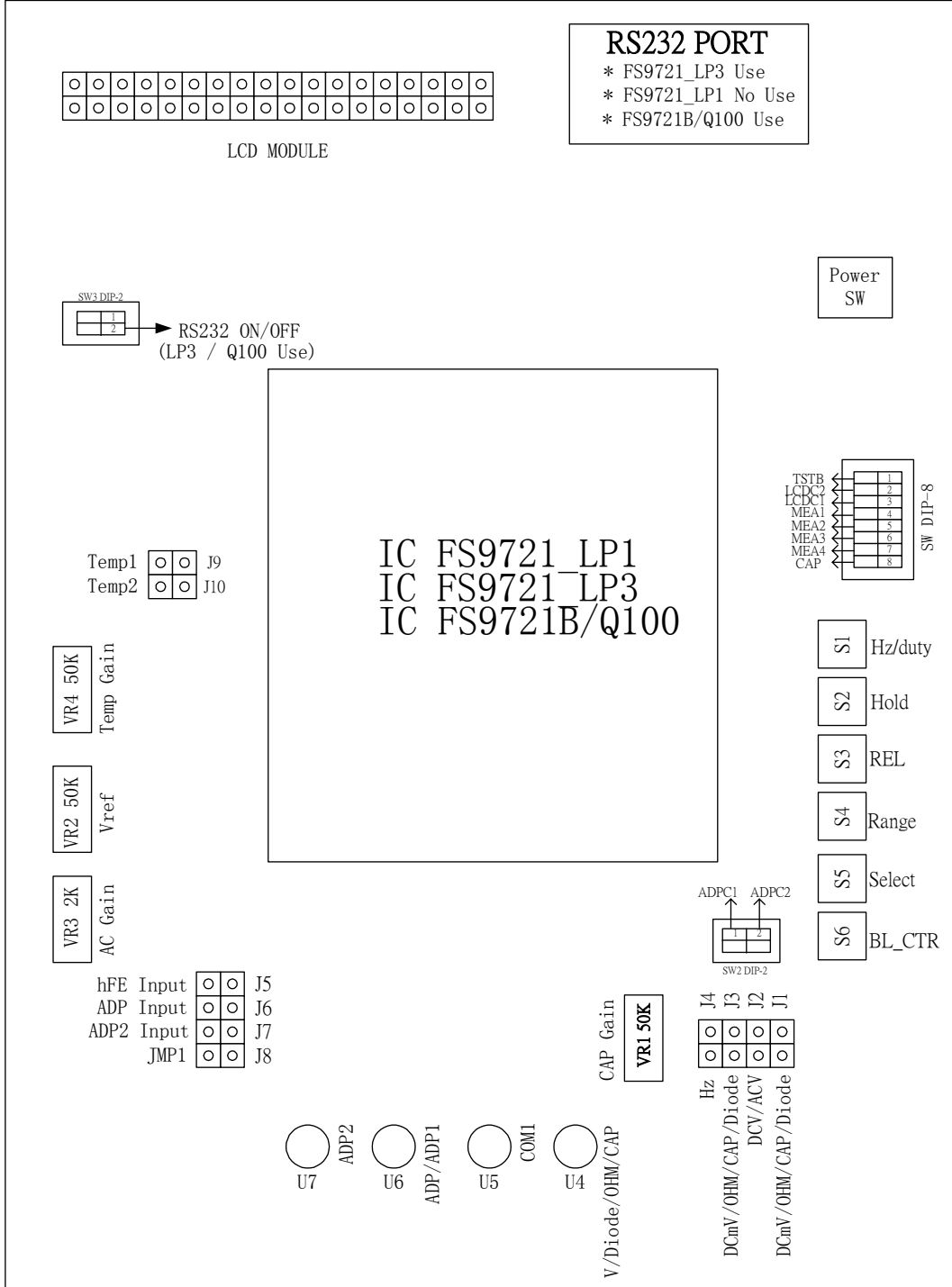

Diagram 35 Demo Board Schematic

- 17.2.1 U4: Input Voltage, Resistance, Diode and Capacitance.
 17.2.2 U5: Analog Signal to Ground.
 17.2.3 U6: Input Voltage (mV), Hz and Duty Cycle.
 17.2.4 U7: Current Mode Measuring Terminal. (Input Voltage)
 17.2.5 J1~J10: Please refer to "FS9721_LP3 Measurement Mode and Jumper Setup".
 17.2.6 S1~S5: Please refer to "FS9721_LP3 Demo Board Schematic".
 17.2.7 SW-DIP8: (If switch SW to ON, it is Low Level)

CAP	Function mode (MEAS → 1101)
1	Ohm / Diode /Cont.
0	Ohm / Diode /Cont. / CAP

MEA4	MEA3	MEA2	MEA1	Function mode
1	1	1	1	DC/AC Voltage (including DC mV mode)
1	1	0	1	Ohm/Diode/Cont./CAP
1	0	1	0	DC Voltage (no DC mV mode)
1	0	0	1	AC Voltage
1	0	1	1	DC mVmode
1	0	0	0	10A
1	1	1	0	mA
1	1	0	0	μA
0	1	1	1	Capacitance Mode
0	1	0	1	Hz/Duty
0	0	D1	D0	ADP
0	1	1	0	ADP
0	1	0	0	ACA(400.0A, 4000A)

- 17.2.8 LCDC1、LCDC2 can control LCD symbol. It shows as below in demo board:

LCDC1	LCDC2	LCD Symbol
0	0	T1
1	0	hFE
0	1	°C
1	1	T2

TSTB	Function Mode (MEAS = 1000) (MEAS = 1110) (MEAS = 1100)
1	* Input Voltage (400mV~4V)
0	* Input Voltage (40mV~400mV)

- 17.2.9 To input (400mV~4V), the conditions are (TSTB=1) & (J3,J8 Short)
 Ex : (MEAS=1100) & (Input : V/Diode/Ohm/CAP,COM)

Input Voltage	LCD Display(μA)
40mV	40.0
400mV	0400
4.00V	4000

17.2.10 To input (40mV~400mV), the conditions are (TSTB=0) & (J3,J8 Open)
Ex : (MEAS=1100) & (Input : ADP2,COM)

Input Voltage	LCD Display (μ A)
4.0mV	40.0
40.0mV	0400
400.0mV	4000

17.2.11 W2-DIP2: (If switch SW to ON, it is Low Level)

ADPC1	Function mode (MEAS \rightarrow 0 0 D1 D0)
1	Input (40mV~400mV)
0	Input (4mV~40mV)

ADPC2	Function mode (MEAS \rightarrow 0 0 D1 D0)
1	DC measurement
0	AC measurement

17.2.12 W3-DIP2: (If switch SW to ON, it is Low Level) * Pin2 Don't care

1 Pin	Function
1 Pin = 1	RS232 mode off
1 Pin = 0	RS232 mode on

17.2.13 FS9721_LP3 Measurement Mode Select:

MEA4	MEA3	MEA2	MEA1	Mode	Select (1 \rightarrow 0 \rightarrow 1)	Hz/duty (1 \rightarrow 0 \rightarrow 1)
1	1	1	1	DC/AC Voltage (including DC mV mode)	DC / AC Switch	Hz/Duty/Voltage Switch
1	1	0	1	Ohm/Diode/Cont./CAP	CAP=1: Ohm/Diode/Cont. Switch	
					CAP=0: Ohm/Diode/Cont./CAP Switch	
1	0	1	0	DC Voltage (no DC mV voltage mode)		Hz/Duty/Voltage Switch
1	0	0	1	AC Voltage		Hz/Duty/Voltage Switch
1	0	1	1	DC mVmode		Hz/Duty/Current Switch
1	0	0	0	10A *4	AC/DC Switch	Hz/Duty/ Current Switch
1	1	1	0	mA *4	AC/DC Switch	Hz/Duty/ Current Switch
1	1	0	0	μ A *4	AC/DC Switch	



FS9721_LP3

4,000 counts auto range DMM IC.

0	1	1	1	Capacitance Mode		
0	1	0	1	Hz/Duty Cycle *1		Hz/Duty
0	0	D1	D0	ADP *2		
0	1	1	0	ADP *3		
0	1	0	0	ACA (400.0,4000)		

17.2.13.1 Hz and Duty Cycle measurements take ADP measuring path as input terminal.

17.2.13.2 ADP is single ADC positive input point. The range of measuring voltage is $\pm 400\text{mV}$. LCD decimal location is decided by D1 and D0. 11 means no decimal, 01 means 40.00, 10 means 400.0 and 00 means 4.000 that display with one unit.

17.2.13.3 ADP can be 400.0mV/40.00mV autoranging to display respectively 4000 and 400.0.

17.2.13.4 When TSTB=1, the current mode is as FS9711_LP1 to input 400mV/4V; when TSTB=0, the current mode is as FS9711B to input 40mV/400mV.

17.2.14 FS9721_LP3 Measurement Mode and Jumper Setup: (1 Pin = TSTB Open)

MEA4	MEA3	MEA2	MEA1	Mode	Jumper	Input
1	1	1	1	DC/AC Voltage (including DC mV mode)	J2	V/Diode/OHM/CAP, COM
1	1	0	1	Ohm/Diode/Cont./CAP	J1,J3	V/Diode/OHM/CAP, COM
1	0	1	0	DC Voltage (no DC mV voltage mode)	J2	V/Diode/OHM/CAP, COM
1	0	0	1	AC Voltage	J2	V/Diode/OHM/CAP, COM
1	0	1	1	DC mV mode	J1	V/Diode/OHM/CAP, COM
1	0	0	0	10A *4	J3,J8	V/Diode/OHM/CAP, COM
1	1	1	0	mA *4	J3,J8	V/Diode/OHM/CAP, COM
1	1	0	0	μA *4	J3,J8	V/Diode/OHM/CAP, COM
0	1	1	1	Capacitance Mode	J1,J3	V/Diode/OHM/CAP, COM
0	1	0	1	Hz/ Duty Cycle *1	J4, J6	ADP/ADP1,COM
0	0	D1	D0	ADP *2	J6	ADP/ADP1, COM
0	1	1	0	ADP *3	J6	ADP/ADP1, COM
0	1	0	0	ACA (400.0,4000)	J3,J8	V/Diode/OHM/CAP, COM

18.Ordering Information

Product Number	Description	Package Type
FS9721_LP3		Die form (78 pins)
FS9721_LP3		100-pin QFP (Not Pb free package)
FS9721_LP3-PCE	Pb free package part number.	100-pin QFP (Pb free package)



FS9721_LP3

4,000 counts auto range DMM IC.

19.Revision History

Ver.	Date	Page	Description
1.5	2004/04/09	3-4, 32	<ol style="list-style-type: none"> Change file name format from "FS9721_LP3 Data Sheet_V1.4.doc" to "FS9721_LP3_DataSheet_V15.doc". Change page top and bottom space format. Add numbers on Features and Application Field on page 3 and 4. Add CR-004 on the bottom page space. Add ordering information.
1.6	2004/11/18	8	1. Revise the Diagram 3 78PIN Dice.
		33	2. Add revision history on the last page of the data sheet.
1.7	2005/7/11	8	1. Diagram 3 78PIN Dice in Ver. 1.6 is not correct. Revise it to the right one.
		32	1. Revise ordering information. Add Pb-free package part number.
1.8	2005/8/9	4	<ol style="list-style-type: none"> Delete 5.120nF Capacitance measurement mode. Correct Frequency measurement mode 5000 counts for 5120counts.
		10	1. In the "9.Technical specification", correct Capacitance measurement mode 4000 counts for 5120counts, and delete 5.120nF measurement mode.
		12,30	1. In the 10.3, LCDC1 and LCDC2=10 display COM2 and SEG14 (hFE). LCDC1 and LCDC2=01 display COM3 and SEG14(°C).
		19	1. Delete diagram 11 "4.5V power supply "and diagram 12 "6.0V power supply",and modify serial number after them.
		26	1. In the 15.17 Capacitance measurement,delete the segment"in actual application.....".
		30-32	1. In the 17.2.7, 17.2.13 and 17.2.14, correct MEAS=1111 AC/DC voltage for DC/AC voltage .Correct MEAS=1011 DCmA mode for DCmV mode.